

Model of Grid connected PV Power Generation Inverter Control System

M. S. Thakare¹, M. D. Khardennis², V.M.Jape³

M Tech scholar¹, Assistant Proffessor², Associate Proffessor³

mdeshmukh13@yahoo.com¹,manishakhardennis@rediffmail.com²,jape.vasant@rediffmail.com³

Abstract— This paper presents the experimental model of grid connected PV power generation inverter control system. On the basis of experimental study of power output side of photovoltaic grid connected generator system, the effectiveness of improved PWM inverter control method is analyzed. Considering the result of experiments, a single phase grid connected Improved PWM inverter control system is designed. The result of the simulations performed using MATLAB/SIMULINK software shows that the improved PWM inverter control system can effectively control the grid current sine waveform using the less computationally demanding harmonic suppression technique. It can achieve the maximum power point tracking. The simulations are performed for a 10 volts system and after analyzing the simulation results, the system is implemented in hardware. After the comparison of simulation model and actual hardware for 10 volts system we implemented the system for 1000 volts. The proposed hardware is able to put the arbitrary power out to the load or to the grid to maintain the stability and reliability of the power system.

Index Terms— PV Power generation, Improved PWM Inverter, photovoltaic cells.

1. INTRODUCTION

Due to the increasingly urgent energy issues, the world attaches great importance to begin the development of new energy and related technology. At present, large-scale photovoltaic power generation and scale of renewable energy has become important parts of development strategy, meanwhile it is the way to guide the development of photovoltaic industry [1],[2]. However, because of its different characteristics from conventional power generation, grid-connected PV power station and its security, stability and reliable operation became new challenges which power grid and PV power plant need to face.

The paper describes improved PWM inverter control method [3]. Voltage source inverter control method regulates phase angle of the grid mainly through receiving voltage signals from DC side of inverter which is called the outer loop to control the grid voltage, while it regulates the voltage reference from the AC side load voltage to control the inverter output current which is called the inner loop [4]. However, the process of the inner loop will not affect the results of the outer loop. Power-type PWM inverter bridge circuit formed by the two groups, which uses two reverse diodes synchronized transformation. Required power can be obtained by changing the modulation rate of PWM inverter. Therefore, whether the grid-connected PV generation inverter control system is able to achieve the maximum power point tracking (MPPT) and to ensure high power quality of

the photovoltaic cells or not are the key issues in electric power system [5]. This paper is presenting a single phase grid connected Improved PWM inverter control system.

2. GRID-CONNECTED PV GENERATION SYSTEM

A. GRID-CONNECTED PV GENERATION SYSTEM

Grid-connected PV generation system is mainly composed of the PV array, the inverter device with the function of maximum power tracking and the control system. The inverter device with the function of maximum power point tracking can inverse the electric power into sinusoidal current, and connect to the grid [6]. The control system mainly control the maximum power point tracking of photovoltaic, current waveform and power of the output of grid-connected inverter, which makes the output to the grid correspond with the export by PV array.

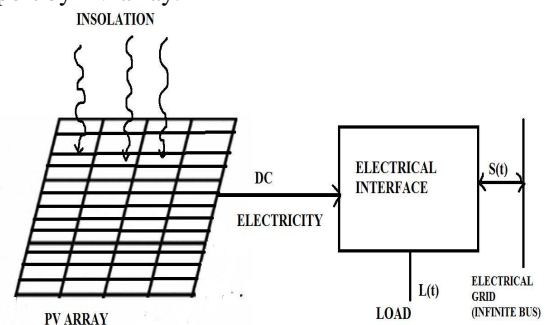

Fig. 1 Grid-connected PV power generation structure

B. INVERTER CONTROL THEORY

Inverter can control the switch state of shut and conduct, thus the system may form two different working ways which are parallel operation and independent operation. When the system is working in a parallel operation way, the inverter belongs to the current mode.

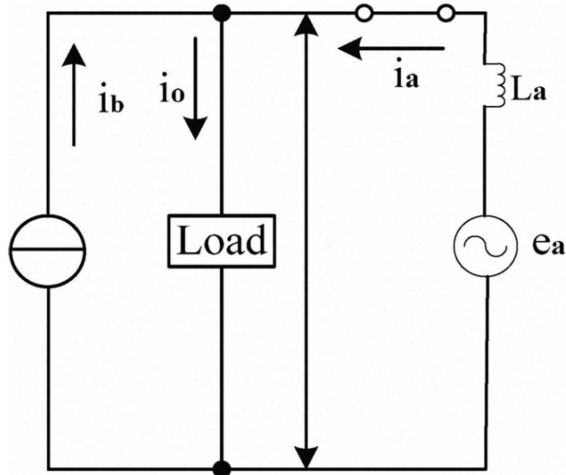

Fig. 2 Equivalent circuit of the inverter in parallel operating mode

C. WORKING OF PV CELL

Working of PV cell is based on the basic principle of photoelectric effect. Photoelectric effect can be defined as a phenomenon in which an electron gets ejected from the conduction band as a consequence of absorption of the sunlight of certain wavelength by the matter. So, in a photovoltaic cell when sunlight strikes its surface, some portion of the solar energy is absorbed in the semiconductor material. If absorbed energy is greater than the band gap energy of the semiconductor, the electrons from the valence band jumps to the conduction band. By this, pair of hole electrons are created in the illuminated region of the semiconductor. The electrons thus created in the conduction band are now free to move. These free electrons are forced to move in a particular direction by the action of electric field present in the PV cell. These flowing electrons constitutes current and can be drawn for external use by connecting a metal plate on top and bottom of PV cell. This current and voltage created because of its built in electric fields produces required power.

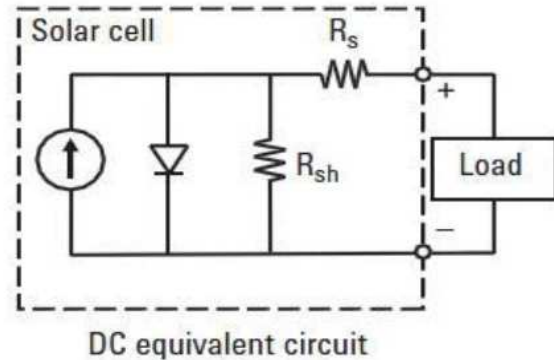

Fig. 3 D.C Equivalent Circuit.

The photovoltaic cell output voltage is basically functioning of the photocurrent which is mainly determined by load current depending on the solar irradiation level during the operation.

$$VC = (A * K * TC / e) \ln[(I_{ph} + I_0 - I_C) / I_0] - R_S * I_C$$

The symbols used are

VC = cell output voltage

TC = reference cell operating temperature

RS = series resistance of cell

I_{ph} = photocurrent, function of irradiation level and junction temperature

I₀ = reverse saturation current of the diode

I_C = cell output current

3. INTRODUCTION OF IMPROVED PWM INVERTER CONTROL METHOD

There are two inverter control methods 1) voltage source inverter control method 2) power type PWM inverter control method.

In the power type PWM inverter control system, abolishing two reverse diodes it becomes improved PWM inverter control method that can save a lot in the control system. The setting of the drive voltage phase of the inverter is based on the grid voltage phase which means the output power factor will be kept to a high value. The improved PWM inverter control system uses the outer loop to control voltage and the inner loop to control current which is the same with the voltage source inverter control. It tracks the maximum power point after using the output current transforms to a fit type, which can ensure maximum power output of the battery [7]. In this way, the system inverter structure is simpler than the power-type PWM, and ensures the stability of the power output.

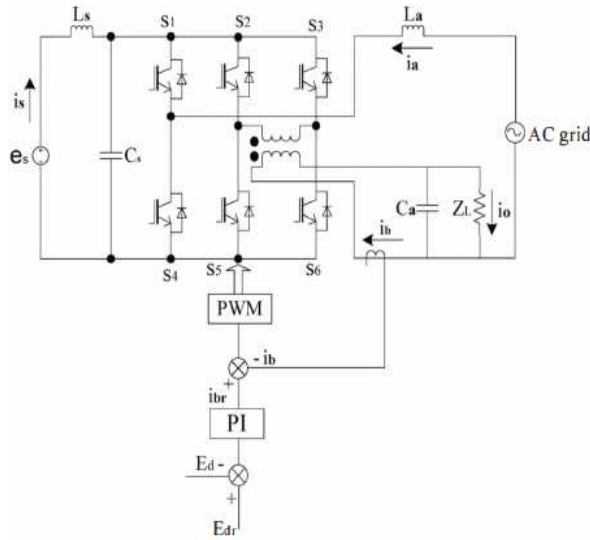

Fig. 4 Improved type PWM Inverter Control System.

4. IMPROVED PWM INVERTER CONTROL SYSTEM FOR 10 VOLT

A. Simulation

The simulation mainly use MATLAB/Simulink software to build a single-phase grid-connected PV generation system, which combines with the improved type PWM inverter control method, the structure is shown in Fig. 5. The system is mainly composed of PV array module, IGBT inverter module, LC filter module and PWM regulator module.

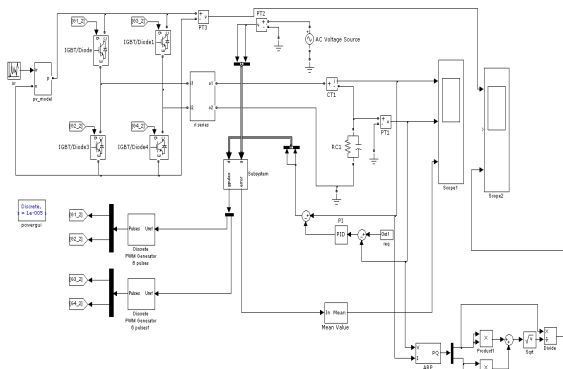

Fig.5 Single-phase PV grid-connected generation system

In the example, the voltage of PV cell is set to 10V, the load is in form of resistance and inductance whose resistance is set to 10 Ω, and the inductance is set to 0.5mH which is equivalent to 7W. PWM regulator controls the current of inverter through using the outer loop to control voltage and using the inner loop to control current, whose modulation index is 0.8. The load current and the output voltage of inverter can be got by calculation. The load current effective value is

0.7A, while the output voltage effective value of inverter is 0.707 V. PV array output voltage curve, Grid-connected load voltage curve and Grid-connected load current curve, load P.F, load Error are shown in Fig.8, Fig .9, Fig. 10, Fig 11 and Fig. 12 separately.

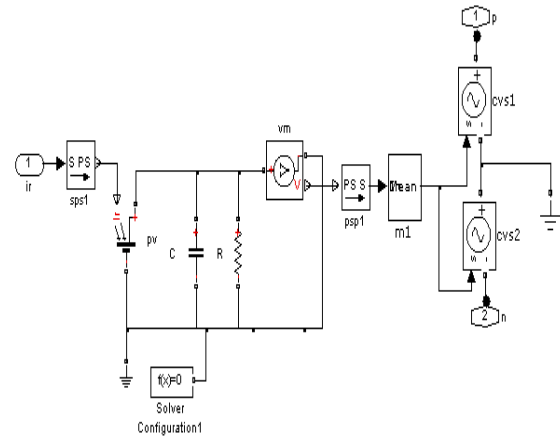

Fig. 6 PV Model

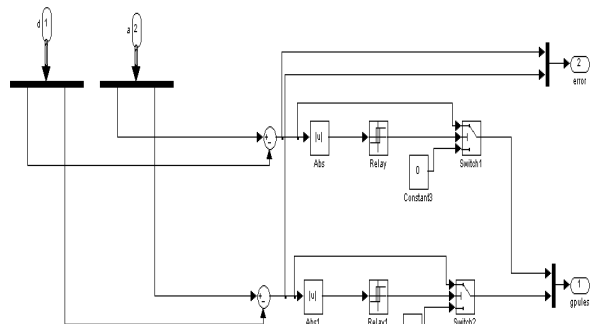

Fig. 7 Comparator

B. System Outputs

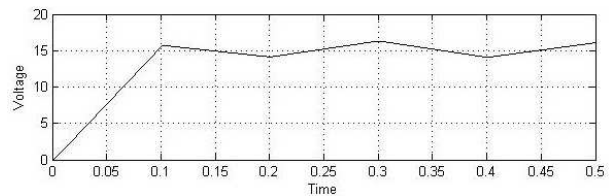

Fig. 8. Output voltage of PV Cell

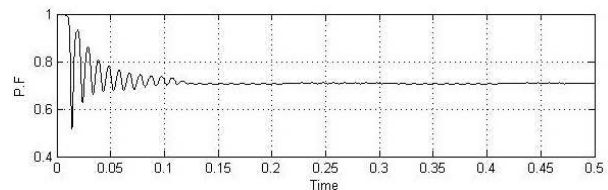

Fig. 9. Output power factor .

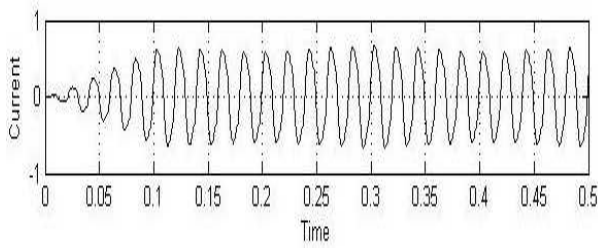

Fig. 10 Grid connected load voltage Curve

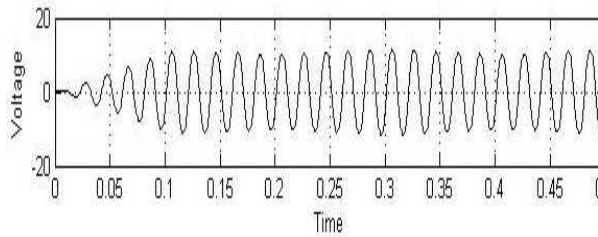

Fig. 11 Grid connected load current Curve

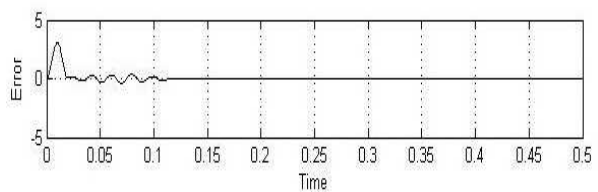

Fig. 12 Grid connected load Error Curve

Fig. 10 and Fig. 11 are the load voltage curve and load current curve separately. From the two curves, operating voltage and current are unstable up to 0.3 sec and then return to near-sinusoidal waveforms quickly, which shows the improved PWM inverter control method can achieve a stable output power better and faster. The power is arbitrary sent to the grid through controlling the PWM regulator, after analyzing the spectral; the power factor will reach to 0.95, which is fully satisfied with the requirement of PV grid-connected generation.

C. Hardware Implementation

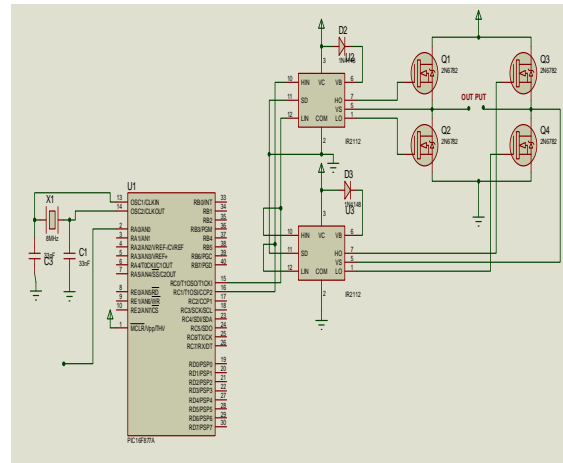

Fig. 13. Hardware Implementation-1

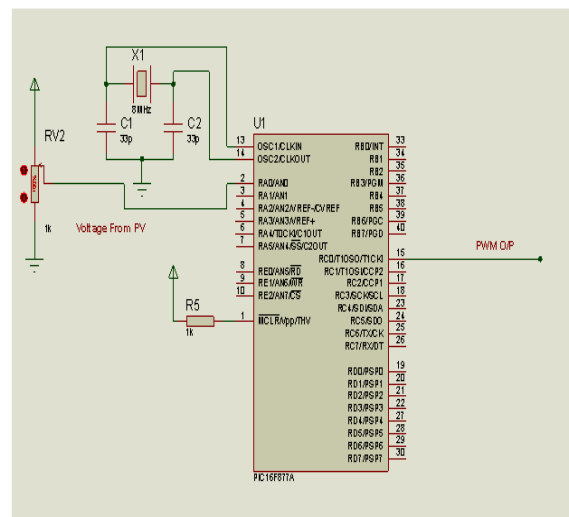

Fig. 14. Hardware Implementation-2

D. Hardware Outputs

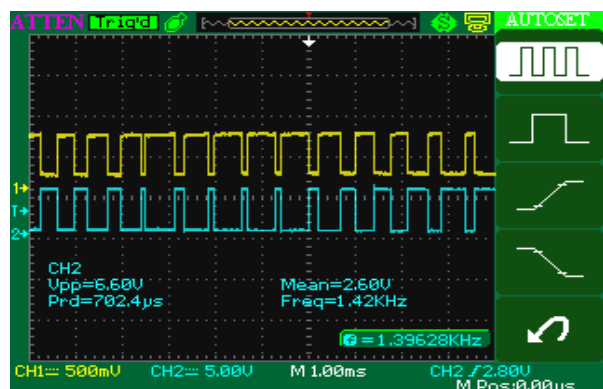

Fig. 15. Graph for power generating in MW

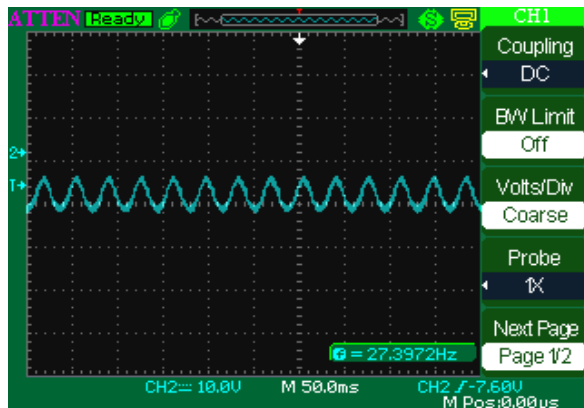

Fig. 16. Graph For convertor output (voltage & current)

5. IMPROVED PWM INVERTER CONTROL SYSTEM FOR 1000VOLTS

A. Simulation

The simulations are performed for a 10 volts system and after analyzing the simulation results, the system is implemented in hardware. After the comparison of the simulation model and actual hardware for 10 volts system, the system is implemented for 1000 volts. The simulation mainly uses MATLAB/Simulink software to build a single-phase grid-connected PV generation system, which combines with the improved type PWM inverter control method. The structure is shown in Fig. 17.

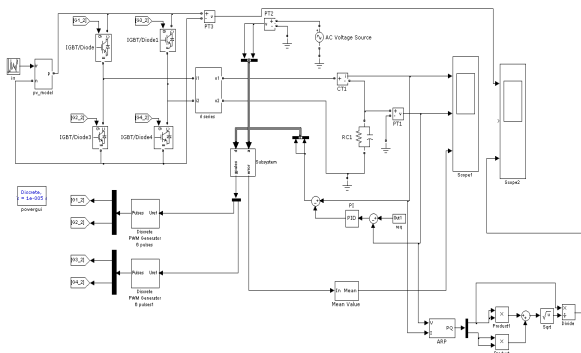

Fig. 17 Single-phase PV grid-connected generation system

In the example, the voltage of PV cell is set to 1000V, the load is in form of resistance and inductance whose resistance is set to 100 Ω , and the inductance is set to 50mH which is equivalent to 500W. PWM regulator controls the current of inverter through using the outer loop to control voltage and using the inner loop to control current, whose modulation index is 0.8. The load current and the output voltage of inverter can be got by calculation. The load current effective value is 37A, while the output voltage effective value of inverter is 800V. PV array output voltage curve, Grid-connected load voltage curve and Grid-connected load current curve, load P.F, load Error are shown in Fig.18 ,Fig. 19, Fig. 20, Fig 21 and Fig. 22 separately.

B. System Outputs

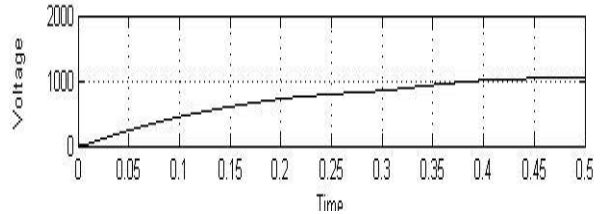

Fig. 18. Output voltage of PV Cell

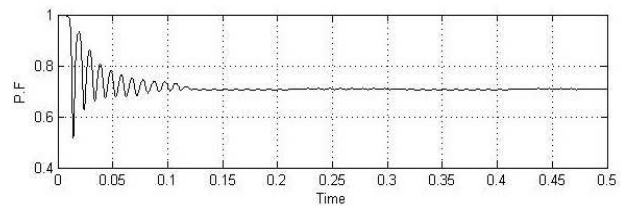

Fig. 19. Output power factor

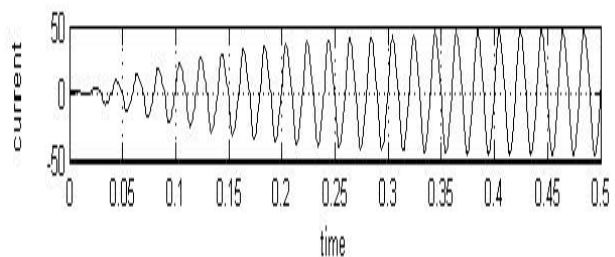

Fig. 20 Grid connected load current Curve

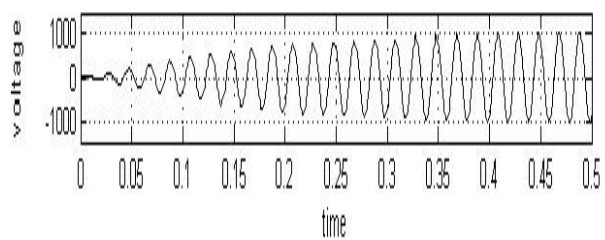

Fig. 21 Grid connected load voltage Curve

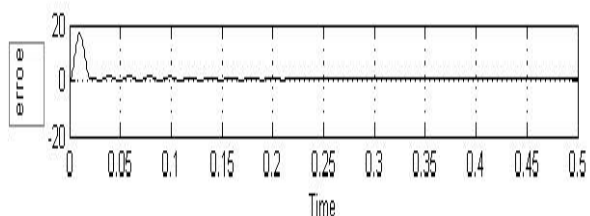

Fig. 22 Grid connected load Error Curve

The proposed hardware is able to put the arbitrary power out to the load or to the grid to maintain the stability and reliability of the power system.

The system is mainly composed of PV array module, IGBT inverter module, LC filter module and PWM regulator module.

6. CONCLUSION

Improved PWM inverter control system is based on the voltage type control method and the PWM power type control method. The result of simulation and conclusions shows that the improved PWM inverter control method can make the voltage and the current waveform of the grid tend to sine wave effectively and quickly, and the power factor will reach to one. The power can be sent to the grid or load arbitrary through controlling the PWM regulator, while the control system has a good stability. It also shows that as the increasing number of inductive load penetrate the grid, the load waveform distortion is produced, but it will not affect the reliability of power supply.

REFERENCES

- [1] Amirnaser Yazdani, Prajna Paramita Dash. "A control methodology and characterization of dynamics for a photovoltaic(PV) system interfaced with a distribution network," IEEE Trans. Power Delivery, vol. 24, pp. 1538-1551, Jul. 2009.
- [2] Yun Tiam Tan, Daniel S.Kirchen, Nicholas Jenkins. "A model of PV Generation Suitable for Stability Analysis". IEEE Transactions on Energy Conversion, vol. 19, pp. 748-755, Dec. 2004
- [3] Hiroshi Yamashita, Keita Tamahashi, Masakazu Michihira, Akiara Tsuyoshi, Kuniyuki Amako, Minwon Park. "A novel simulation technique of the PV generation system using real weather conditions," Power Conversion Conference, pp. 839-844, 2002.
- [4] M. Park, K.Matsuura, M. Michihira. "A Novel Simulation Method of PV cell using Field Data", Trans. of IEEE Japan, 121-B, No.2, pp.262-263(200 I).
- [5] AKotsopoulos, J.L.Duarte, M.AM. Hendrix. "A predictive control scheme for DC voltage and AC current in grid-connected photovoltaic inverters with minimum DC link capacitance". The 27th Annual Conference of the IEEE Industrial Electronics Society, pp. 1994-1999. .
- [6] H.S.Bae, SJ.Lee, K.S.Cho, S.SJang. "Current control Design for a Grid Connected Photovoltaic/Fuel Cell DC-AC Inverter". IEEE Trans. On Energy Conversion, pp. 1945-1950, 2009.
- [7] O.Wasneuk, N.AAnwah. "Modeling and Dynamic Performance of a Self-commutated Photovoltaic Inverter System". IEEE Trans. on Energy Conversion, vol. 4, NO.3, pp. 322-328, Sep. 1989.

BIOGRAPHIES

Mahesh.S.Thakare received Degree in Electrical Engg. from Y.C.College of Engineering,Nagpur(M.S.),India. .Presently; he is an M Tech (EPS) student at Govt. College of Engineering, Amravati (M.S.), India.

Prof. M.D.Khardennis received the B.E. degree in electrical engineering from R.K.N.E College of Engg Nagpur,(M.S.).,She IS Industrial experience of 9 year. From 2002 working as Asist.Prof. at Govt. College of Engineering, Amravati (M.S.), India .The research area are Transmission expansion Planning.

Prof. V.M.Jape received the B.E. degree in electrical engineering Govt. College of Engineering, Amravati (M.S.). he had also Completed his M.E from VJTI Mumbai .Total Teaching experience of 26 year working as Associate Professor The research area are Control system & Drives.